

Main controller + 100MHz radio

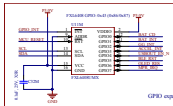

GPIO expanders with interrupt handling

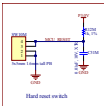

Hardware reset switch

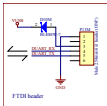

FT232RL header

DC address

0x00000000: 0x00000000
 0x00000004: 0x00000000
 0x00000008: 0x00000000
 0x0000000C: 0x00000000
 0x00000010: 0x00000000
 0x00000014: 0x00000000
 0x00000018: 0x00000000
 0x0000001C: 0x00000000

SPI usage wires

0x00000000: 0x00000000
 0x00000004: 0x00000000
 0x00000008: 0x00000000
 0x0000000C: 0x00000000
 0x00000010: 0x00000000
 0x00000014: 0x00000000
 0x00000018: 0x00000000
 0x0000001C: 0x00000000

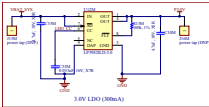
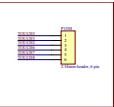
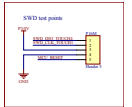

Licensed under CERN OHL v1.2 or later
 Copyright 2015 Andrew "bunnie" Huang

OpenLab IoT Platform (bedcamp) EV11

Rev	Date	Author
1.0		

Revision: 1.0



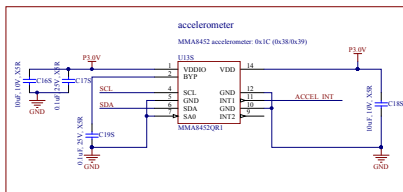
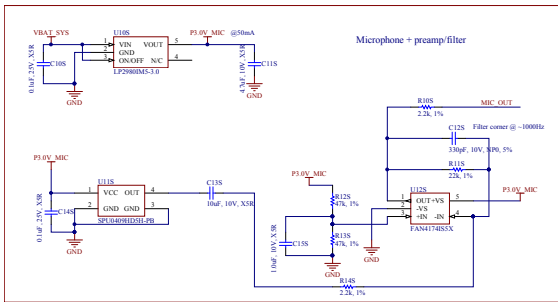

Licensed under CERN OHL v1.2 or later
 Copyright 2015 Andrew "bunnie" Huang



Title		
Orchard IoT Platform (bootcamp) EVT1		
Size	Number	Revision
A		
Date:	5/27/2015	Sheet of
File:	F:\angework_01\sempro_Sch1.doc	Drawn By

Note: OLED requires VBAT_SYS > 3.5V
Ibat = 32mA max, 20mA typ

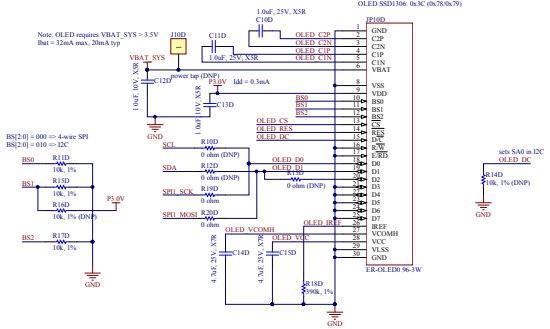

Licensed under CERN OHL v1.2 or later
Copyright 2015 Andrew "bunnie" Huang



Title		
Orchard IoT Platform (bootcamp) EVT1		
Size	Number	Revision
A		
Date	Sheet of	
5/27/2015	1	
File	Drawn By	
F:\engineering\040101_SchDoc		

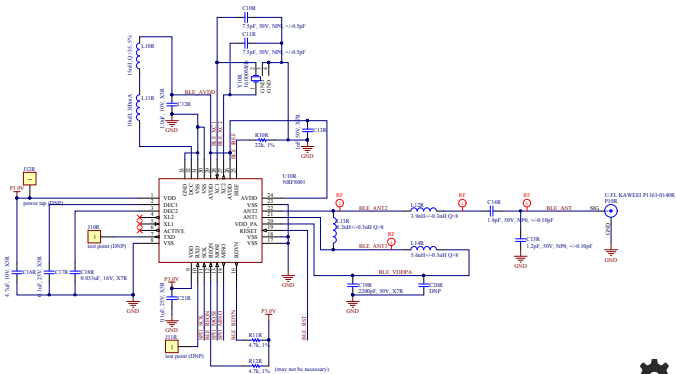

Licensed under CERN OHL v1.2 or later
Copyright 2015 Andrew "bunnie" Huang



Title		
Rev	Number	Revision
Orchard IoT Platform (bootcamp) EVT1		
Date:	2015	Sheet of
File:	Platform_001b_SchDoc	Drawn By:

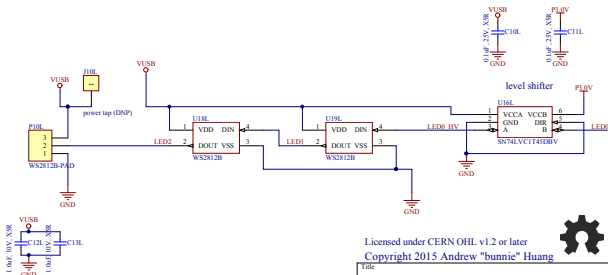

Licensed under CERN OHL v1.2 or later
Copyright 2015 Andrew "bunnie" Huang



Title		
Orchard IoT Platform (bootcamp) EVT1		
Size	Number	Revision
A		
Date	Sheet of	
File	Drawn By	
F:\angework\06led\SchDoc		

MPR121 implemented because captouch electrodes are too far from MCU

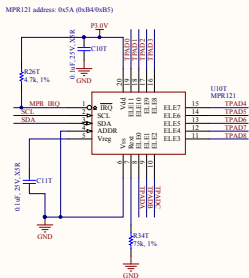

Captouch pads

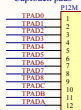

KAWEE1 THD0510-12RL-GF

Licensed under CERN OHL v1.2 or later

Copyright 2015 Andrew "bunnie" Huang



Title		
Orchard IoT Platform (bootcamp) EVT1		
Size	Number	Revision
A		
Date:	5/27/2015	Sheet of
File:	F:\angework_07\captouch SchDoc	Drawn By